

PRODUCT SPECIFICATIONS

Elkay EZH2O® Bottle Filling Station with Integral SwirlFlo® Fountain, Refrigerated Filtered or Non-Filtered Stainless. Features shall include Hands Free, Optional Visual Filter Monitor, Green Ticker™, Laminar Flow, Antimicrobial, Real Drain. Furnished with Flexi-Guard® Safety Bubbler. Electronic Bottle Filler Sensor With Sensor Front Bubbler Button activation. Product shall be Wall Mount (Inwall Frame/Plate), for Indoor applications, serving 1 station(s). Unit shall be certified to UL 399 and CAN/CSA C22.2 No. 120. Unit shall be lead-free design which is certified to NSF/ANSI 61 & 372 (lead free) and meets Federal and State low-lead requirements.

Special Features:	Hands Free, Optional Visual Filter Monitor, Filtered, Green Ticker™, Laminar Flow, Antimicrobial, Real Drain
Finish:	Stainless Steel
Power:	115V/60Hz
Bubbler Style:	Flexi-Guard® Safety Bubbler
Filtration	Filtered or Non-Filtered
Activation by:	Electronic Bottle Filler Sensor with Sensor Bubbler Activation
Mounting Type:	Wall Mount (Inwall Frame/Plate)
Full Load Amps	1
Rated Watts:	15
Dimensions (L x W x H):	19-3/4" x 19" x 34-5/8"
Approx. Shipping Weight:	121 lbs.
Installation Location:	Indoor
No. of Stations Served:	1

- Visual Filter Monitor: LED Filter Status Indicator for when filter change is necessary.
- Filter is certified to NSF 42 and 53 for lead, particulate, chlorine, taste and odor reduction. 3,000 gal. capacity.
- Green Ticker: Informs user of number of 20 oz. plastic water bottles saved from waste.
- Laminar flow provides clean fill with minimal splash.
- Silver Ion Antimicrobial protection on key plastic components to inhibit the growth of mold and mildew.
- Real Drain System eliminates standing water.

PART: _____ QTY: _____
 PROJECT: _____
 CONTACT: _____
 DATE: _____
 NOTES: _____
 APPROVAL: _____



AMERICAN PRIDE. A LIFETIME TRADITION. Like your family, the Elkay family has values and traditions that endure. For almost a century, Elkay has been a family-owned and operated company, providing thousands of jobs that support our families and communities.



Specify Filtration: Filtered or Non-Filtered Integral Bottle Filling Station (EDFPBM14WS-FX),
Complete Product with Listed Components: Sensor Fountain (ENOB8CX), Mounting Frame (MFWS100),

▼ Ships in multiple boxes.

PRODUCT COMPLIANCE

- ADA & ICC A117.1
- ASME A112.19.3/CSA B45.4
- Buy American Act
- CAN/CSA C22.2 No. 120
- GreenSpec®
- NSF/ANSI 42, 53, 61, & 372 (lead free)
- UL 399



Complies with ADA & ICC A117.1 accessibility requirements when installed according to the requirements outlined in these standards. Installation may require additional components and/or construction features to be fully compliant. Consult the local Authority Having Jurisdiction if necessary.

- [Installation Instructions \(PDF\) - 1000003097](#)
- [Installation Instructions \(PDF\) - 0000001030](#)
- [Installation Instructions \(PDF\) - 0000001027](#)

5 Year Limited Warranty on the refrigeration system of the unit. Electrical components and water system are warranted for 12 months from date of installation. **Warranty pertains to drinking water applications only. Non-drinking water applications are not covered under warranty.**

[Warranty \(PDF\)](#)

In keeping with our policy of continuing product improvement, Elkay reserves the right to change product specifications without notice. Please visit elkay.com for the most current version of Elkay product specification sheets. This specification describes an Elkay product with design, quality, and functional benefits to the user. When making a comparison of other producers' offerings, be certain these features are not overlooked.

OPTIONAL ACCESSORIES

51300C - Elkay WaterSentry Plus Replacement Filter (Bottle Fillers)
WSF6000R-2PK - WaterSentry Fresh 6000 CTO Replacement Filter (2pack)
LKAPR1 - Elkay Cane Apron for SwirlFlo Gray

In keeping with our policy of continuing product improvement, Elkay reserves the right to change product specifications without notice. Please visit elkay.com for the most current version of Elkay product specification sheets. This specification describes an Elkay product with design, quality, and functional benefits to the user. When making a comparison of other producers' offerings, be certain these features are not overlooked.

**IMPORTANT!
INSTALLER PLEASE NOTE:**

The grounding of electrical equipment such as telephone, computers, etc., to water lines is a common procedure. This grounding may be in the building or may occur away from the building. This grounding can cause electrical feedback into a water cooler, creating an electrolysis which causes a metallic taste or causes an increase in the metal content of the water. This condition is avoidable by using the proper materials as indicated below. The drain fittings which are provided by the installer should also be plastic to electrically isolate the cooler from the building plumbing system.

OPERATION OF QUICK CONNECT FITTINGS

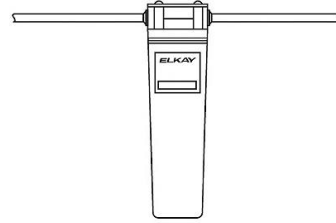
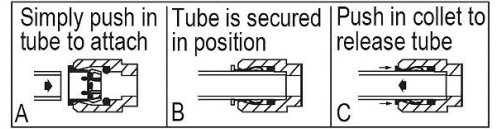

Pushing tube in before pulling it out helps to release tube

WaterSentry[®] Plus Filter System

BOTTLE FILLER SPECIFICATIONS

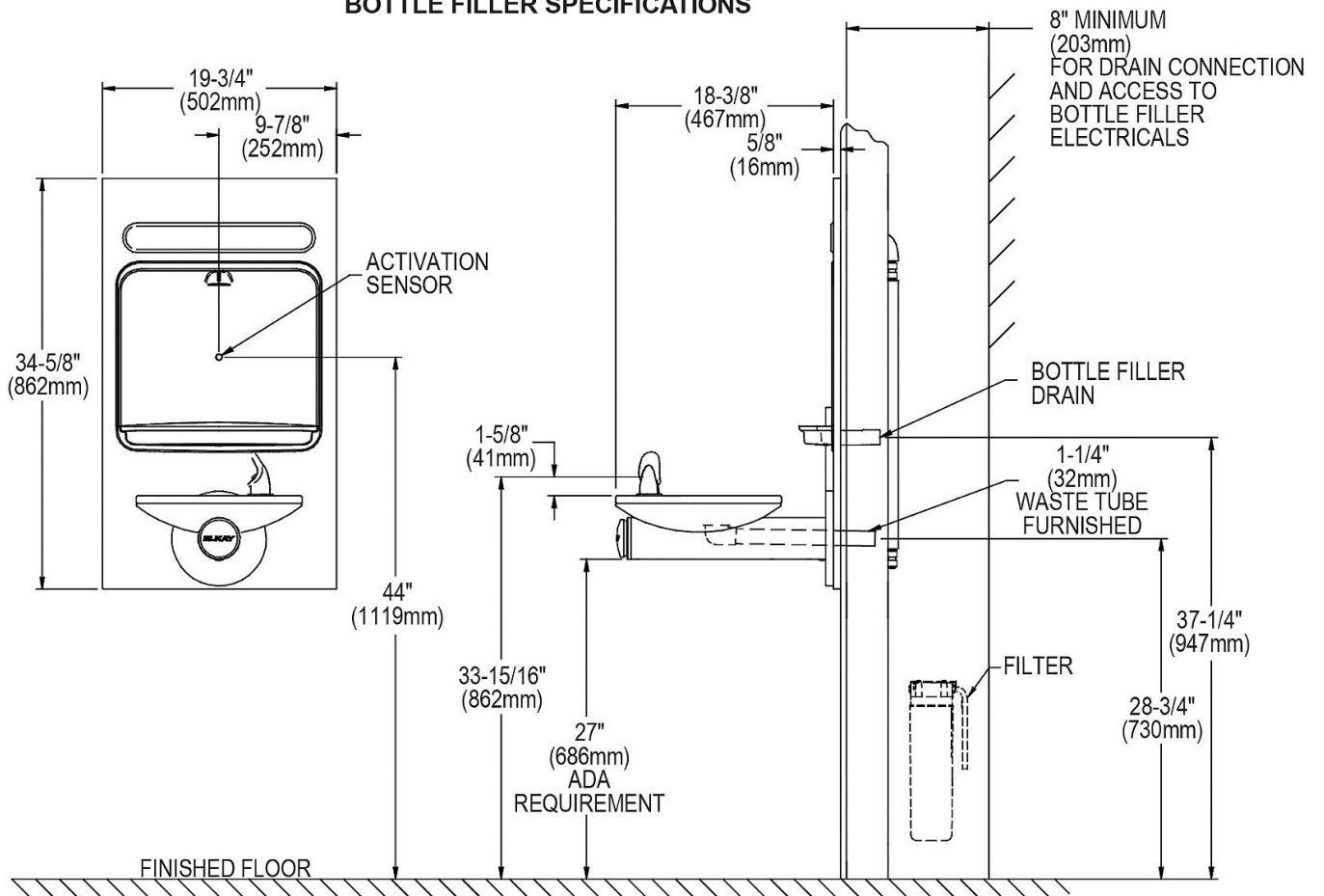

REDUCE HEIGHT BY 3 INCHES FOR INSTALLATION OF CHILDREN'S ADA FOUNTAIN

NOTE : New Installations Must Use Ground Fault Circuit Interrupter (GFCI).

In keeping with our policy of continuing product improvement, Elkay reserves the right to change product specifications without notice. Please visit elkay.com for the most current version of Elkay product specification sheets. This specification describes an Elkay product with design, quality, and functional benefits to the user. When making a comparison of other producers' offerings, be certain these features are not overlooked.

MOUNTING FRAME MFWSF100

INSTALLER NOTE

This drinking fountain is furnished with a bubbler and valve including all connecting fittings which are manufactured of completely lead free material. Shut off valve (not furnished) to accept 3/8" O.D. unplated copper tube.

WALL OPENING

IMPORTANT: It is necessary to create a wall opening 18-3/4" W x 31-3/4" H and 25" above the floor line.

ELECTRICAL DATA

Electrical outlet, three (3) conductor grounded. Locate within safe reach of power cord.

MOUNTING INSTRUCTIONS

Refer to rough-in for location of plumbing and electrical sources. The support frame is to be installed first. Fountain is to be attached to panel and all frame. Water service line, waste line and electrical are assembled as required. Perform a final check for leaks and correct functions of fountain and chiller. (For details see the installation instructions.) Installation requires trap to be installed in wall. Trap and service stop not included.

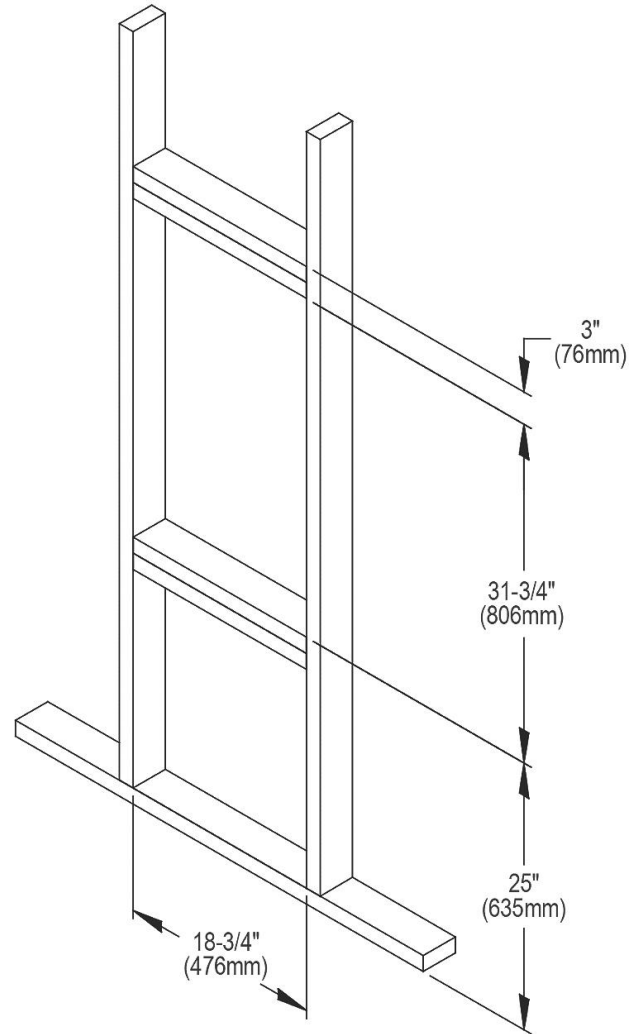
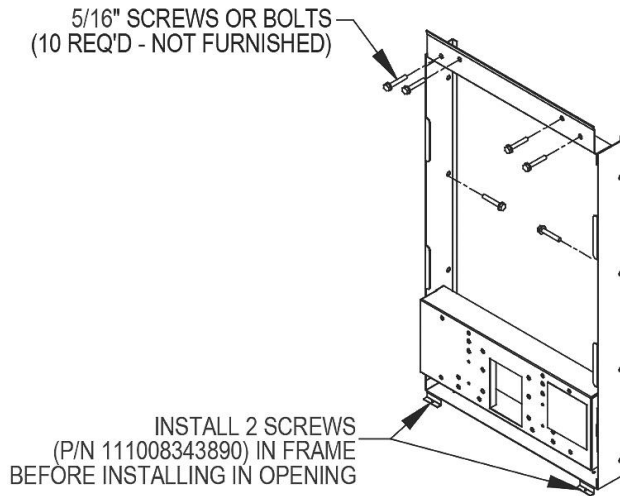

In keeping with our policy of continuing product improvement, Elkay reserves the right to change product specifications without notice. Please visit elkay.com for the most current version of Elkay product specification sheets. This specification describes an Elkay product with design, quality, and functional benefits to the user. When making a comparison of other producers' offerings, be certain these features are not overlooked.